

Published: Feb 23, 2009

Ride and Handling Optimization

COMPONENT LOCATION

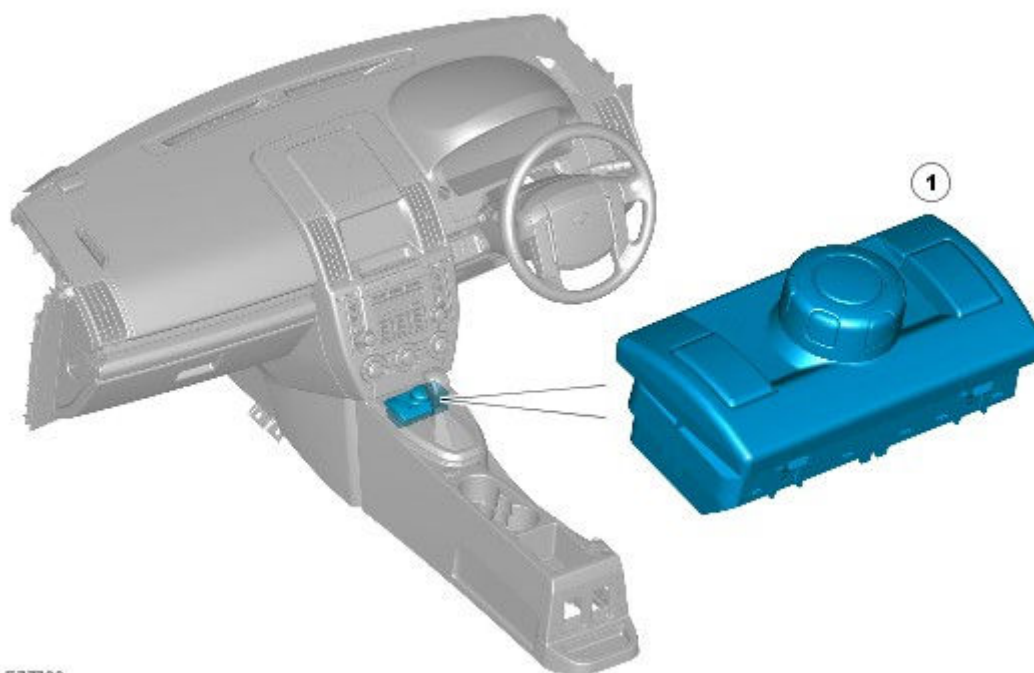

E77783

Item	Part Number	Description
1		Terrain Response rotary control

OVERVIEW

The Terrain Response™ system allows the driver to select a program which aims to provide the optimum settings for traction and performance for the prevailing terrain conditions. The system cannot be switched off. 'Special Programs off' is the default program and covers all general driving conditions. Three specific terrain programs are selectable to cover all terrain surfaces.

The system is controlled by a rotary control located on the center console, forward of the transmission selector lever. The rotary control allows the selection of one of the following 4 programs:

- Special programs off
- Grass/Gravel/Snow
- Mud/Ruts
- Sand.

The rotary control can be rotated through 360 degrees or more in either direction and selects each program in turn. When Terrain Response is fitted to a vehicle, a hi-line instrument cluster will also be fitted which will display the selected program in the message center.

The Terrain Response system uses a combination of a number of vehicle sub-systems to achieve the required vehicle characteristics for the terrain selected. The following sub-systems are used in the Terrain Response system:

- Engine management system
- Automatic transmission (if fitted)
- Electronic center coupling
- Brake system (ABS/DSC/ETC/HDC functions).

The rotary control switch pack also contains the Terrain Response control module. The control module detects the selection made on the rotary control and transmits a signal on the high speed Controller Area Network (CAN) bus which is received by each of the sub-system control modules. Each of the affected control modules contain software

which applies the correct operating parameters to their controlled system for the Terrain Response program selection made. They also provide feedback for the selected program so that the Terrain Response control module can check that all systems have changed to the correct operating parameters.

Information is displayed in the instrument cluster message center which informs the driver of improvements which can be made to the vehicle operating parameters to optimize the vehicle for the prevailing conditions.

Inexperienced off-road drivers may benefit from the automatic assistance of the Terrain Response system and the driver information. Experienced off-road drivers can select the specific programs for extreme conditions to access control over the vehicle systems (for example; accelerator pedal maps, transmission shift maps, traction settings) which are not accessible on vehicles without Terrain Response.

Stop/Start Vehicles - From 2010 MY

Activation of the Terrain Response special programs will deactivate the Stop/Start system.

However, if Terrain Response is activated when the engine is shutdown in a Stop/Start cycle the engine will automatically restart. If during this event the Stop/Start system cannot detect the driver's occupancy, for example either the driver's safety belt or door is unlatched, the engine will not restart. The Stop/Start system will request the driver to depress the clutch to restart the engine. The driver will be informed of this by 'RESTART REQUIRED PRESS CLUTCH' being displayed in the message center. For additional information, refer to [Starting System](#) (303-06C)

TERRAIN RESPONSE ROTARY CONTROL AND MODULE

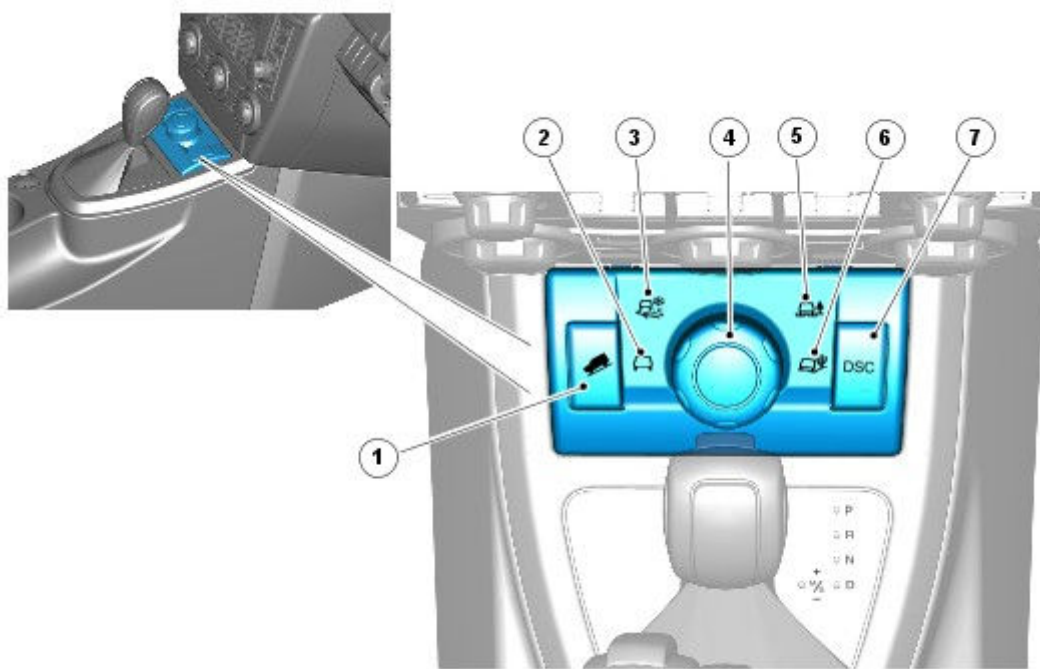

E77784

Item	Part Number	Description
1		Hill Descent Control (HDC) switch
2		Special programs off
3		Grass/Gravel/Snow program
4		Rotary control
5		Mud/ruts program
6		Sand program
7		Dynamic Stability Control (DSC) switch

Each program is denoted by a symbol which represents the terrain encountered. The rotary control will only select the last program in its direction of rotation. Further rotation of the control in either direction, once the last program has been selected, will have no effect, for example; once 'Sand' has been selected, further rotation in a clockwise direction will retain 'Sand'.

The control module and rotary control is connected via a harness connector which also contains the wiring for the HDC and DSC switches and the illumination circuits. The control module and rotary control uses 4 of these wires for 12V battery supply (ignition - only when the ignition is on) a ground and high speed CAN bus (positive and negative).

PRINCIPLES OF OPERATION

The following vehicle sub-system control modules are used for the Terrain Response system:

- Engine management - Engine Control Module (ECM)
- Transmission control - Transmission Control Module (TCM) (automatic transmission only)
- Center coupling control module
- Brake system - Anti-lock Brake System (ABS)/Dynamic Stability Control (DSC)/Electronic Traction Control (ETC)/ Hill Descent Control (HDC) - ABS module

Each sub-system operates in different ways in relation to the selected Terrain Response program to achieve the optimum traction, stability and ease of control for the terrain encountered.

Engine Management System (EMS)

The EMS can change the accelerator pedal maps to change the amount of torque per percentage of pedal travel.

Each terrain program uses a combination of operating parameters for each sub-system. Changing between terrain programs initiates a different set of operating characteristics which will be noticeable to the driver, for example; if the accelerator pedal is held in a constant position and the terrain program is changed from Grass/Gravel/Snow to Sand, the driver will notice the torque and engine speed increase. If the terrain program is changed from Sand to Grass/Gravel/Snow, the driver will notice a reduction in torque and engine speed.

NOTE:

The change in torque and engine speed can take approximately 30 seconds and care must be taken not to confuse the Terrain Response system operation with an EMS fault.

Transmission Control (Automatic transmission only)

The transmission control module changes the shift maps for the Terrain Response program selected. This changes the shift points providing early or late upshifts and downshifts.

For example, in the Grass/Gravel/Snow program, the transmission will perform early upshifts and very late downshifts to ensure the transmission is in the highest gear possible. The hill detection function of the Transmission Control module (TCM) will lock the torque converter and hold whichever gear is selected to the engine speed (RPM) limit if necessary when descending a steep incline. This provides maximum engine braking before the driver needs to apply the brakes.

Sport mode is only available when the general program is selected. Sport mode is disabled in all Terrain Response special programs. 'CommandShift™' is available in any program.

Active On-Demand Coupling Control

The active on-demand coupling control module has 2 operating strategies; pre-emptive and reactive.

The pre-emptive strategy anticipates and predicts the locking torque value required to minimize slip and maximize stability. Each Terrain Response program has a different threshold and input criteria for the pre-emptive strategy. For example, a higher locking torque would be applied on slippery surfaces.

The reactive strategy varies the amount of locking torque in response to the actual slip level and the dynamic behavior of the vehicle. Each Terrain Response program has a different threshold and input for the reactive strategy. The reactive strategy improves vehicle traction and composure by eliminating any wheel spin which has occurred after the pre-emptive strategy was applied. The locking response applied is applicable to the terrain program selected. For example, very sensitive on slippery surfaces to provide maximum traction and minimize surface damage.

The locking torque calculations use various signals from other sub-systems, for example, engine torque, accelerator pedal position, selected gear, steering angle, vehicle speed, lateral acceleration, yaw behavior.

The DSC function of the ABS system can override the active on-demand coupling control and reduce any applied locking torque during DSC action.

ABS System Control

The ABS module controls several functions and adjusts the operating parameters of these functions to optimize the selected Terrain Response program.

Traction Control

Traction control uses different slip/acceleration thresholds to improve traction and vehicle composure. For example, the system sensitivity is increased on slippery surfaces such as wet grass or snow to reduce wheel spin. If wheel spin was allowed in these circumstances, loss of traction may result from surface damage (wet grass) or the car being unable to move (snow) due to wheel spin.

Dynamic Stability Control

If DSC is switched off (with the DSC switch adjacent to the Terrain Response rotary control) when using a Terrain Response special program, if the special program is subsequently changed for a different program, DSC is automatically switched back on.

The DSC uses different threshold values for the selected program to automatically reduce DSC intervention, removing the requirement for the driver to disable the DSC system in order to reduce engine intervention which is sometimes induced in extreme off-road conditions. In extreme sand conditions, there may be an additional benefit of disabling the DSC function using the DSC switch in addition to selecting the sand program.

In the Mud/Ruts program the DSC system is calibrated to tolerate a higher 'yaw' threshold. This allows a greater differential between the actual and desired wheel turning behavior before DSC intervenes. This allows the DSC system to ignore the effect of ruts 'jarring' the car or adjusting the front wheel steering angle.

The Terrain Response system can alter the balance between engine and brake intervention. For example, when the sand program is selected, the DSC system reduces its reliance on engine intervention and increases the use of brake intervention to maintain the vehicles momentum and prevent it from becoming bogged down if wheel slip is detected.

Hill Descent Control

HDC is automatically switched on or off and target speeds are adjusted in response to the Terrain Response program selected. The responsiveness of the HDC function is also increased where required.

Automatic operation of HDC aims to assist the driver by switching the system on or off when it is of most benefit. HDC is only automatically switched on when the mud/ruts program is selected. HDC is not automatically selected in other programs.

Incorrect Program Usage

Selection of an inappropriate program is discouraged in the following ways:

- The active program icon is continually displayed in the instrument cluster message center
- The Terrain Response control module 'locks' out certain functions in some programs, for example: cruise control is only available with the special programs off or grass/gravel/snow program transmission 'Sport' mode is deactivated in all special programs.
 - cruise control is only available with the special programs off or grass/gravel/snow program
 - transmission 'Sport' mode is deactivated in all special programs.
- When the ignition has been in the off mode, continually for more than 6 hours, the Terrain Response system defaults to the special programs off.

Selection of an inappropriate program for the terrain conditions will not endanger the driver or cause damage to the vehicle. Continued use of an inappropriate program may reduce the life of some components. The driver may notice reduced vehicle response, with the engine and transmission being less responsive than in special programs off. Also, in some programs, HDC will remain on, signified by illumination of the HDC indicator in the instrument cluster. The driver may also notice torque 'wind-up' in the center coupling causing a braking effect when the vehicle is manoeuvred in some special programs.

Driver Information

The high-line instrument cluster fitted to all vehicles with Terrain Response, contains a message center which displays vehicle information to the driver. The message center contains the Terrain Response program icons which display the currently selected program. If no symbol is displayed, no special program is selected and the system is in 'Special programs off'.

Any required changes to the sub-systems are also passed to the driver in the form of indicator illumination in the instrument cluster or appropriate messages in the message center, 'HDC OFF' for example.

In certain operating conditions, the Terrain Response system also displays advice or warning messages to ensure the driver is using the vehicle to its full potential, for example, steering angle is displayed in the message center to avoid driving in deep ruts with steering lock applied.

DIAGNOSTICS

The Terrain Response control module stores information on detected Terrain Response faults and CAN errors which can be interrogated using IDS. The Terrain Response sub-systems and the instrument cluster also store information relating to CAN errors from the Terrain Response control module.

The control module also stores the miles traveled and time elapsed for the individual programs which can also be retrieved using IDS. This information aids diagnosis of the Terrain Response system and also provides an indication of Terrain Response system abuse by the driver which can lead to premature component failure.

This information can also be used to check customer concerns, for example, high fuel consumption which may be due to continued use of a certain program.

Terrain Response System Fault Diagnosis

Terrain Response relies on the correct functionality of the 4 sub-systems. If one of the sub-systems develops a fault, the Terrain Response system will not function, even though the fault is **NOT** in the Terrain Response system.

The Terrain Response control module and rotary control should only be investigated if there are no apparent faults in any of the sub-systems. If a fault in a sub-system is subsequently corrected, the Terrain Response system will function normally after an ignition mode 1 and 2 (on and off) cycle.

Terrain Response Sub-System Faults

When a fault occurs in a sub-system, the driver is alerted by the illumination of a warning indicator and/or an appropriate message for that sub-system in the instrument cluster message center. There will be no warning of a Terrain Response system fault.

When a sub-system fault is present and the driver attempts to select a different Terrain Response program using the rotary control or at the next ignition mode 2 (on) cycle, a message 'SYSTEM FAULT SPECIAL PROGRAMS NOT AVAILABLE' will appear in the message center. This implies that the Terrain Response system has a fault, but **only because a sub-system fault is preventing its operation**. This message will be displayed for 5 seconds per ignition mode 2 cycle, but is repeated if a further selection is made by the driver using the Terrain Response rotary control or at the next ignition mode 2 (on) cycle.

NOTE:

The message 'SYSTEM FAULT SPECIAL PROGRAMS NOT AVAILABLE' can also be generated by a fault in the Terrain Response rotary control or control module. Refer to the following information for details of rotary control or control module faults.

It is not possible for the Terrain Response control module to cause any fault behavior (warning indicator illumination or message generation) in any of the 4 sub-systems. Illumination of a sub-system warning indicator and/or a sub-system related message will **NEVER** be associated with a Terrain Response control module or Terrain Response system fault.

The sub-system control modules can detect a fault with the CAN signal from the Terrain Response control module. If a fault in the Terrain Response system is detected, the sub-system control modules will operate in the 'Special programs off' setting. The sub-system control modules will record a fault code for a failure of the Terrain Response CAN signal. These faults can be retrieved using IDS and will provide useful information to indicate investigation of the Terrain Response control module or the CAN network.

Terrain Response Rotary Control or Control Module Fault

If a fault occurs in the Terrain Response rotary control, all rotary control icon amber Light Emitting Diodes (LED's) will be turned off and rotation of the rotary control is ignored. The instrument cluster message center will display a

message 'SYSTEM FAULT SPECIAL PROGRAMS NOT AVAILABLE' when the fault occurs, if the fault is present and the driver attempts to select a special program (if the control module is able to do this) or at the next ignition mode 2 (on) cycle.

The Terrain Response rotary control and the control module are an integral unit. If a fault occurs in either component, the whole unit will require replacement. **ENSURE THAT THE FAULT IS WITH THE TERRAIN RESPONSE CONTROL MODULE AND NOT IN A SUB-SYSTEM MODULE BEFORE REPLACING THE MODULE.**

If a CAN fault exists and prevents Terrain Response system operation, all of the Terrain Response rotary control icon LED's will be illuminated and rotation of the rotary control is ignored.

If the instrument cluster does not receive a Terrain Response system CAN message from the Terrain Response control module, the message 'SYSTEM FAULT SPECIAL PROGRAMS NOT AVAILABLE' will be displayed when the fault occurs and will be repeated at every ignition mode 2 (on) cycle.

User Error

The following incorrect usage of the system may be misinterpreted as a system fault:

- Engine not running - Program changes and driver advisory messages are only available with the engine running
- Special program change attempted with DSC or ABS active (this includes ABS cycling which is operational when HDC is being used on slippery or loose surfaces)
- Special program change attempted with overheat condition present on the active on-demand coupling.