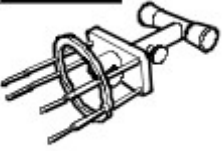

Climate Control - Blower Motor LHD AWD

Removal and Installation

Special Tool(s)

 <p>412-140 E89027</p>	<p>412-140 Remover/Installer, Blower Motor</p>
---	--

Removal

1. **NOTE:** The recirculation blend door must be closed in order for the removal of the recirculation blend door housing.

Activate recirculation.

2. Disconnect the battery ground cable.

Refer to: [Specifications](#) (414-00 Battery and Charging System - General Information, Specifications).

3. Remove the accelerator pedal assembly.

Refer to: [Accelerator Pedal](#) (310-02 Acceleration Control, Removal and Installation).

4.

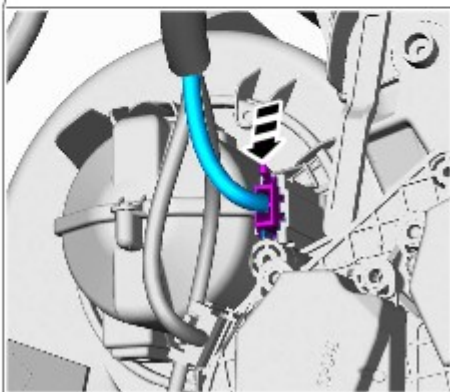
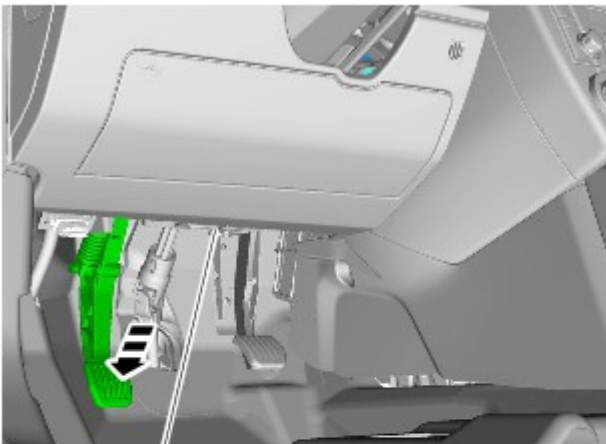

E88858

5. Remove the glove compartment.

Refer to: [Glove Compartment](#) (501-12 Instrument Panel and

Console, Removal and Installation).

6.

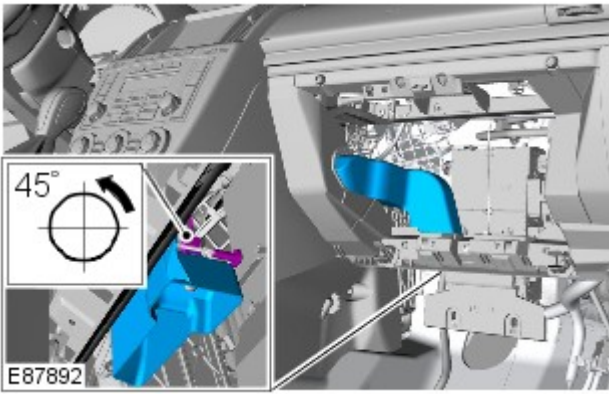

7.

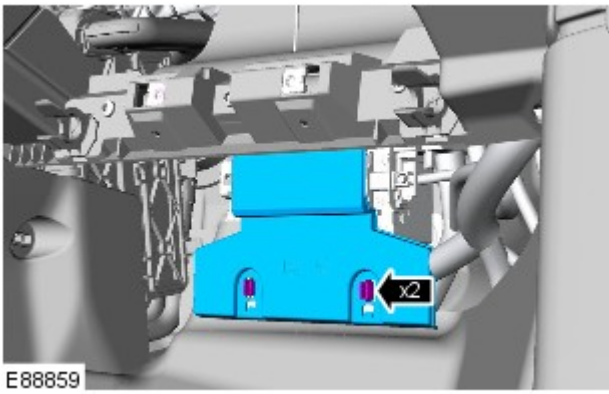

8.

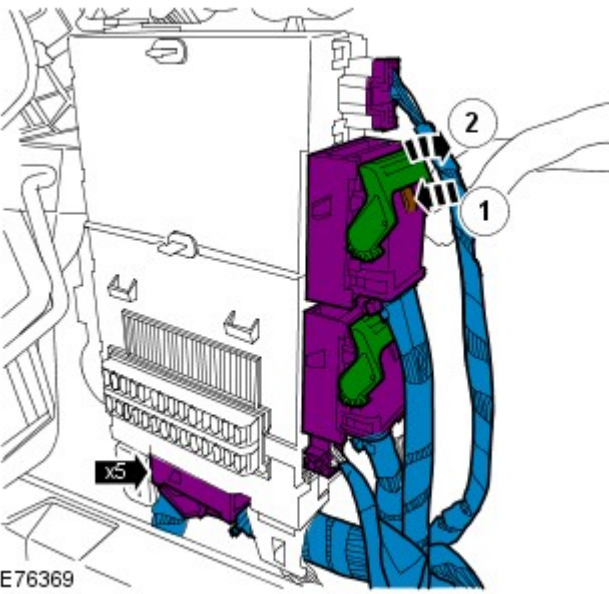

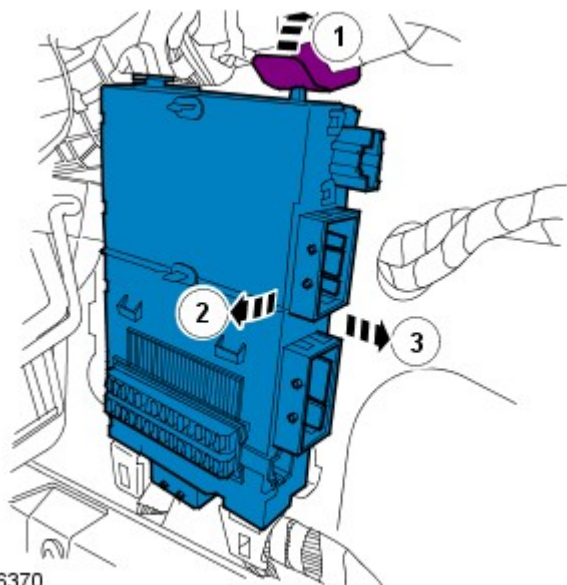

E76370

9.

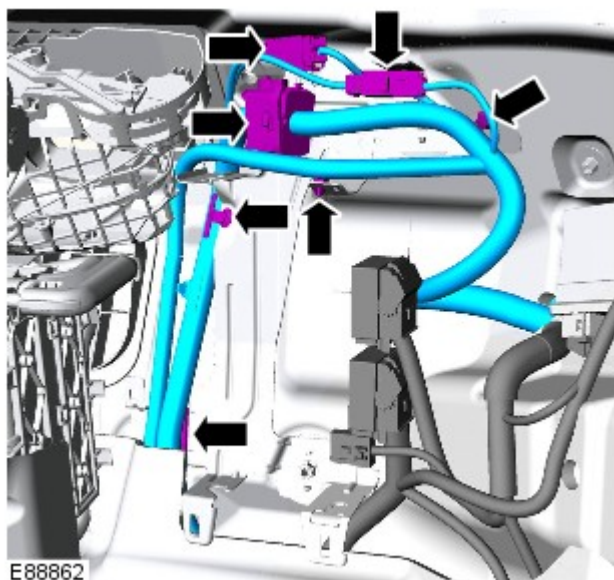

E88862

10.

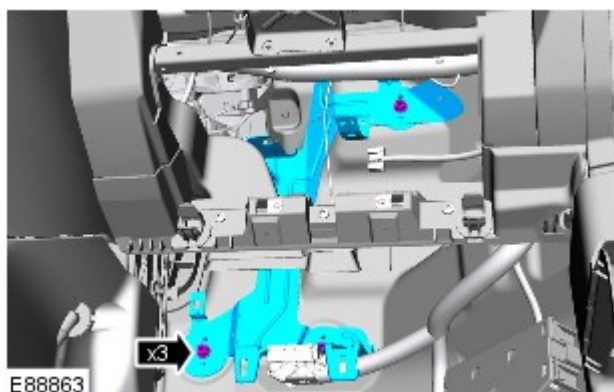

E88863

11. Remove the CJB bracket.

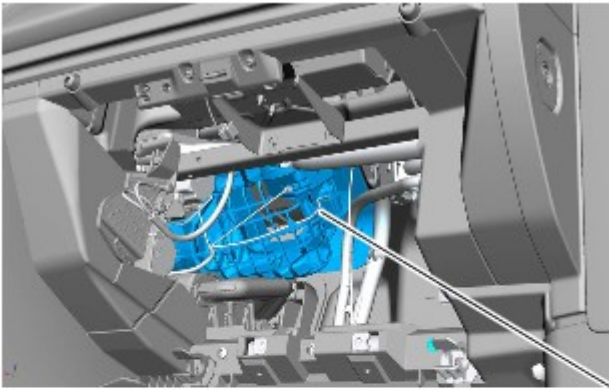

12.

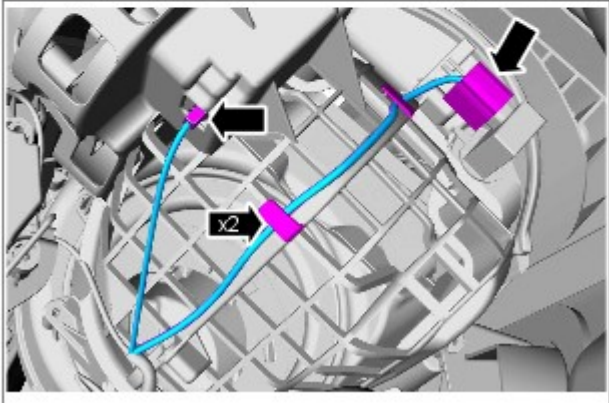

E88864

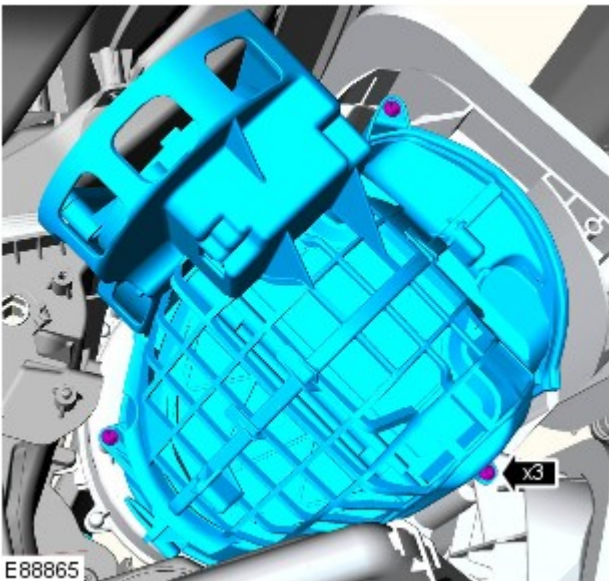

13.

E88865

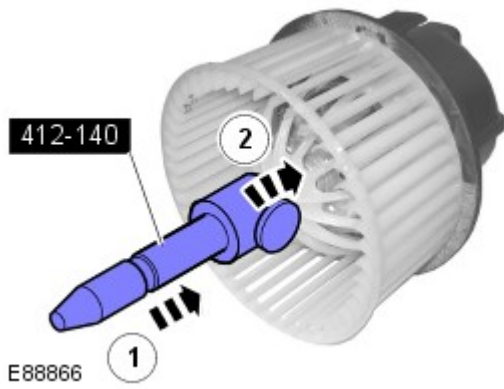

14. Install the special tool guide to the blower motor.

Special Tool(s): [412-140](#)

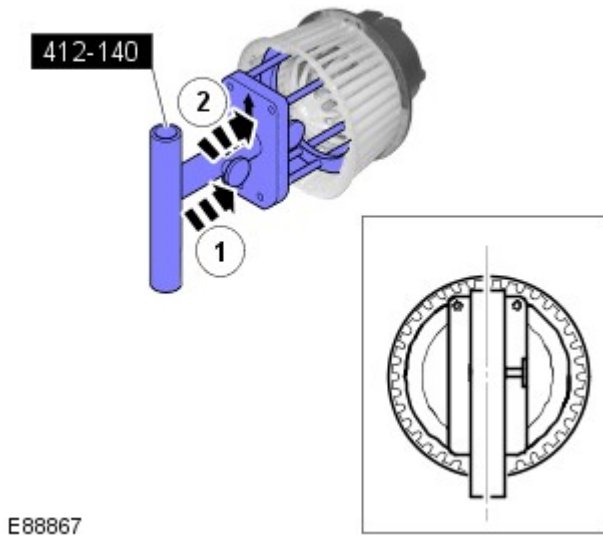

15. With the marking upwards, use the guide to install the remainder of the special tool to the blower motor.

Special Tool(s): [412-140](#)

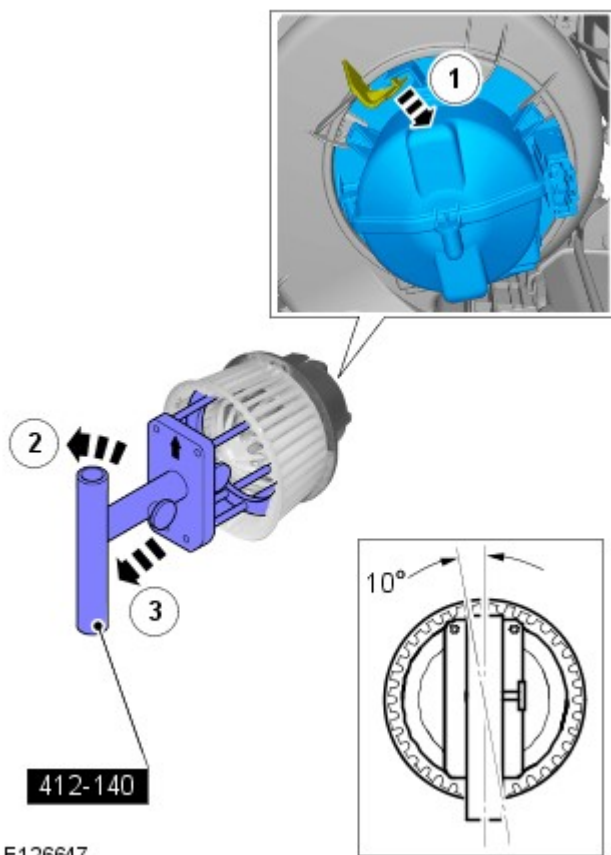

E126647

Installation

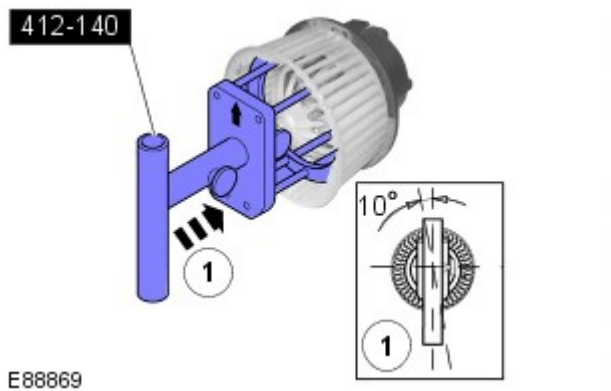

E88869

16. **16.**  **CAUTION:** Make sure that the special tool is correctly located.
- Rotate the special tool counter-clockwise to release the blower motor assembly.
 - *Special Tool(s):* [412-140](#)
 - Remove the blower motor assembly.
 - Release the blower motor locking tang.

1. Using the special tool, install the blower motor assembly approximately 10 degrees counter-clockwise from the vertical position.

Special Tool(s): [412-140](#)

2. Rotate the special tool clockwise to secure the blower motor assembly.

Special Tool(s): [412-140](#)

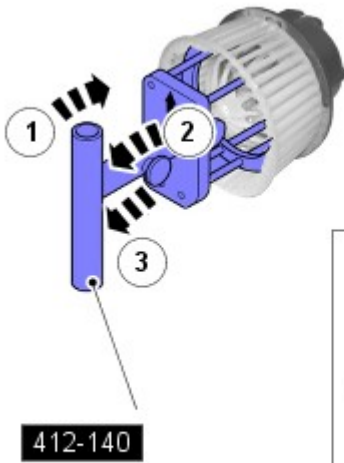

E88870

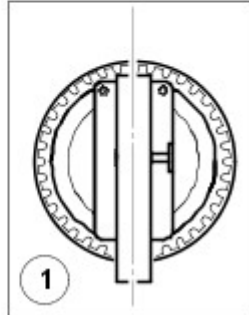

3. Install the recirculation blend door housing assembly.

4.
 - Connect the recirculation blend door actuator electrical connector.
 - Connect the air quality sensor electrical connector.
 - Secure the wiring harness.

5. Install the CJB bracket.

Torque: 10 Nm

6. Secure the wiring harnesses to the CJB bracket.

7. Install the CJB.

8. Connect the 5 electrical connectors to the CJB and secure the front carpet.

9. Install the CJB lower access cover.

10. Install the passenger side footwell duct.

11. Install the glove compartment.

Refer to: [Glove Compartment](#) (501-12 Instrument Panel and Console, Removal and Installation).

12. Connect the blower motor electrical connector.

13. Install the accelerator pedal assembly.

Refer to: [Accelerator Pedal](#) (310-02 Acceleration Control, Removal and Installation).

14. Connect the battery ground cable.

Refer to: [Specifications](#) (414-00 Battery and Charging System - General Information, Specifications).